

ARC ENERGY LTD HOVEA PRODUCTION FACILITY

Engineering Design, and Project Management, Dongara, Western Australia

ARC Energy's Hovea Production Facility is located near Dongara, approximately 380 km north of Perth, Western Australia.

ICON Engineering was commissioned in late 2002 by ARC Energy to perform engineering design and preparation of engineering documents such as process flow diagrams, P&IDs, and multidiscipline design. ICON's role then expanded to include:

- Project management including bid and award of procurement and construction packages.
- Preparation of operating procedures and documentation for regulatory authorities.
- Assistance with construction supervision.
- Commissioning of the facilities.



The initial 8,000 bbl/day 3 Phase Separator.

The Hovea Production Facility started operation with 3 wellheads, a single separator, oil storage tanks and loadout facilities. Crude oil produced through the facility is trucked south to BP Refinery at Kwinana.

The initial development was undertaken as an early production test as the field performance could not be predicted. Thus the water production and the field life were both determined during the development phase.

As the development was funded from cash flow rather than debt, a staged development focussing on low initial expenditure was important. Second hand equipment has been used where appropriate.

Since starting in December 2002, ICON enabled expansion of the facility to include a water injection system, further separation (2 additional separators), more wells (local and remote) and artificial lift (gas lift). ICON has also introduced the concept of dual fuel drivers for water pumps and generators to allow standard diesels to run on gas/diesel or straight diesel. The cost of this conversion paid for itself within 3 months.

As well as the challenges relating to the undefined performance of the field, the crude had a high pour point thus requiring it to be kept warm.

ICON was involved in the detail design, construction management and commissioning of all the facilities. Each of these expansion projects has been fast-tracked with tight budget constraints.



Two Waukesha Gas Engine-Driven (1215 hp) Ariel Compressors used for Gas Lift at ARC's Hovea Facility.

The Main Control Centre (MCC) was designed for continuous operations, and is a 'stand alone' centre with full control and monitoring of all facility parameters.

ICON Engineering worked closely with ARC Energy on a risk reward basis to ensure successful project delivery in all cases.

Subsequent to development of the facility, ICON continued to support Arc Energy during the operation of the field in a "brownfield" environment. ICON assisted Arc in developing

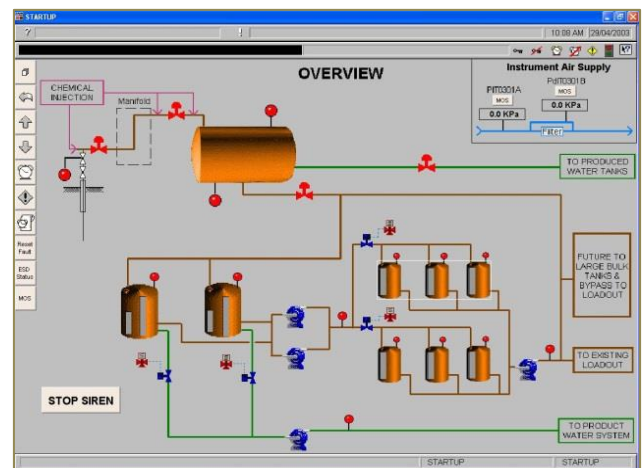

The first of several Graphical User Interface displays for the ICSS.

operating procedures, change management and project screening procedures.

Drawings and key documents were made available on the ICON Extranet system allowing managed access to the latest information over the internet.